

NOTES:

1. TO INSPECT ASSEMBLY, FOLLOW FIRST ARTICLE AND IN PROCESS INSPECTION SHEET.

2 APPLY PERMANENT THREAD LOCKER (LOCTITE 680)

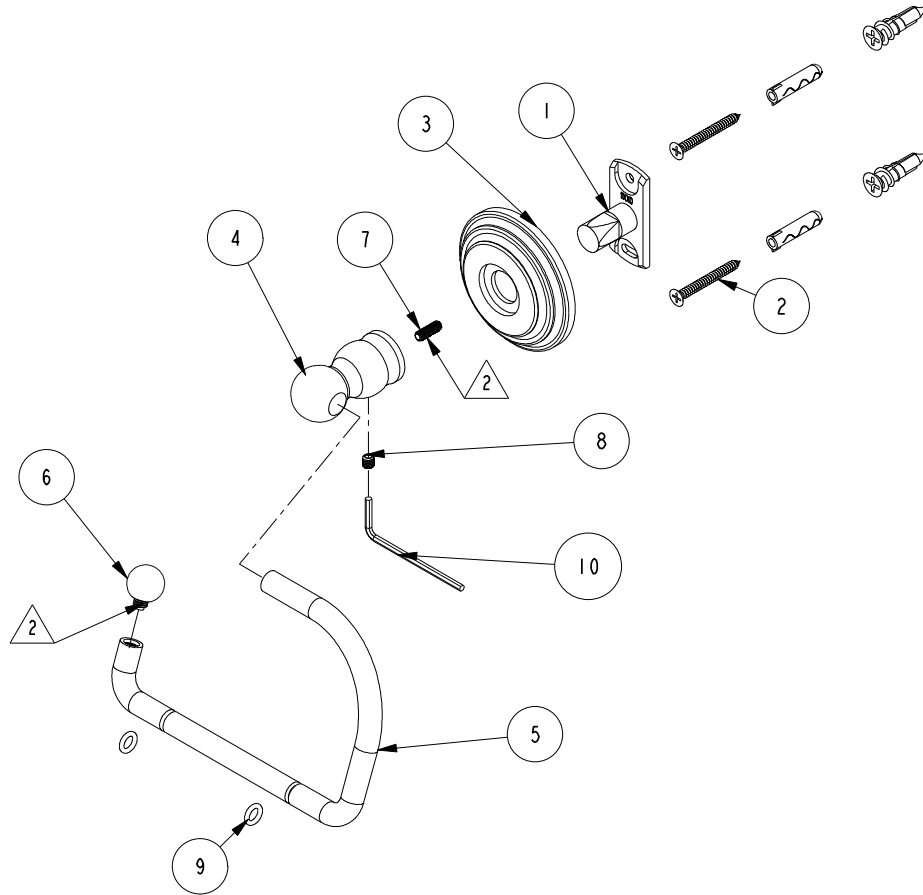

BILL OF MATERIAL (CURRENT LEVEL)

ITEM	PT/ASSY	DESCRIPTION	TYPE	QTY.
1	11XXD	SOLID MOUNTING BRACKET	PART	1
2	1-206	HARDWARE PACK	ASSEMBLY	1
3	1100C	TOWEL SHELF ROSETTE	PART	1
4	40750	POST - OPEN TOWEL RING	PART	1
5	40757	HANGING TISSUE BAR	PART	1
6	40754	FINIAL	PART	1
7	92486	SCRW, 8-32 X 1/2 SKT HD CUP PT SS	PART	1
8	92308	SCRW, M5 X 5 SKT HD CUP PT W/ SELF LOC SS	PART	1
9	91578	O-RING, 2 X 6MM ID, EPDM, 65-75 DURO	PART	2
10	10888	HEX KEY, 2.5MM ALLOY STEEL	PART	1

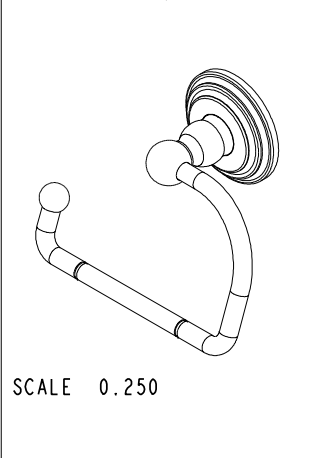

ZONE	REV	DESCRIPTION	DATE	APPROVED
-	A	EN-4378	07/27/21	R. S.
-	-	RELEASED	02/01/04	-

COPYRIGHT 2005 BRASSTECH, INC. THESE DRAWINGS AND THE DESIGNS DEPICTED HEREIN ARE THE PROPRIETARY PROPERTY OF BRASSTECH. ANY USE OR REPRODUCTION IS SUBJECT TO THE EXPRESS APPROVAL OF BRASSTECH. UNAUTHORIZED USE IS STRICTLY PROHIBITED. ALL RIGHTS RESERVED.

TESTING	ASSEMBLY	PLATING	POLISHING	MACHINING	TOOLING FIXTURE #	APPLICATION
-	-	-	-	-	-	REMOVE ALL BURRS AND SHARP EDGES

UNITS ARE:	INCHES	[MM]
TOLERANCES ARE:	FRACTIONS	DECIMALS
	±1/16"	.XX ±.06
	.X ±.1	[2.5]
		[1.5]
		±1°
(X.XXX)	DENOTES CRITICAL DIMS.	
ALL THREADS ARE CRITICAL		
DRAWN	R.S.	7/26/19
CHECKED	J.M.	7/26/19
APPROVED	J.M.	7/26/19

BRASSTECH 2001 CARNEGIE AVE. SANTA ANA, CA 92705 (949) 417-5207
INCORPORATED

HANGING TP HOLDER

DWG NO. **1109** REV **A**

SCALE .312 REF. - SHEET 1 OF 2

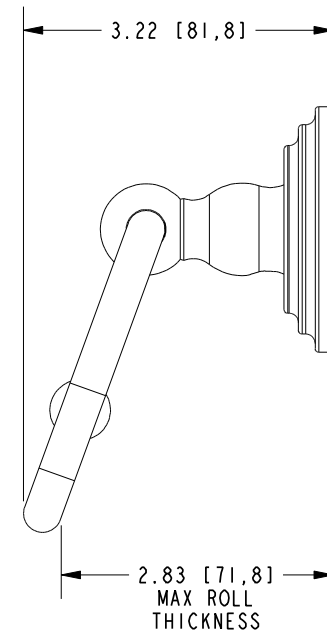
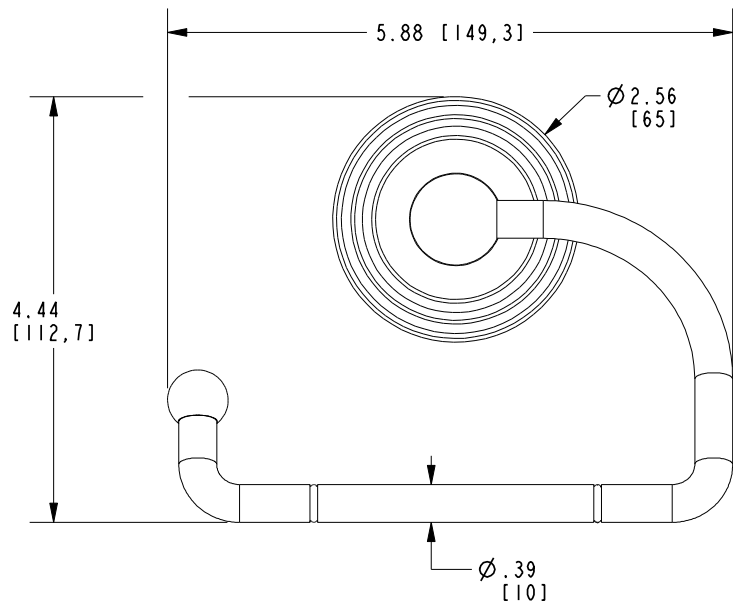
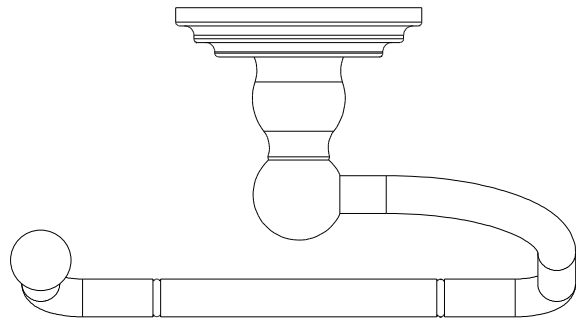

BRASSTECH		2001 E. CARNEGIE AVE. SANTA ANA, CA 92705 (949) 417-5207	
DWG NO.	1109	REV	A
SCALE	.500	REF.	-
		SHEET	2 OF 2