

NOTES:

1. TO INSPECT ASSEMBLY, FOLLOW FIRST ARTICLE AND IN PROCESS INSPECTION SHEET.

2. APPLY LOCTITE 680.

BILL OF MATERIAL (CURRENT LEVEL)

ITEM	PT/ASSY	DESCRIPTION	TYPE	QTY.
1	11XXD	SOLID MOUNTING BRACKET	PART	1
2	1-206	HARDWARE PACK	ASSEMBLY	1
3	1100C	TOWEL SHELF ROSETTE	PART	1
4	40752	POST - TOWEL RING	PART	1
5	40890	HANGING TISSUE BAR	PART	1
6	40891	FINIAL	PART	1
7	92486	SCRW, 8-32 X 1/2 SKT HD CUP PT SS	PART	1
8	92308	SCRW, M5 X 5 SKT HD CUP PT W/ SELF LOC SS	PART	1
9	91578	O-RING, 2 X 6MM ID, EPDM, 65-75 DURO	PART	4
10	10888	HEX KEY, 2.5MM ALLOY STEEL	PART	1
11	40889	TISSUE HOLDER HOOD	PART	1

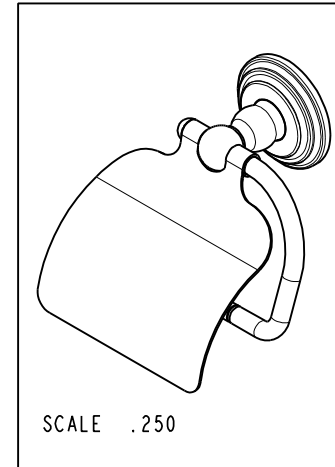
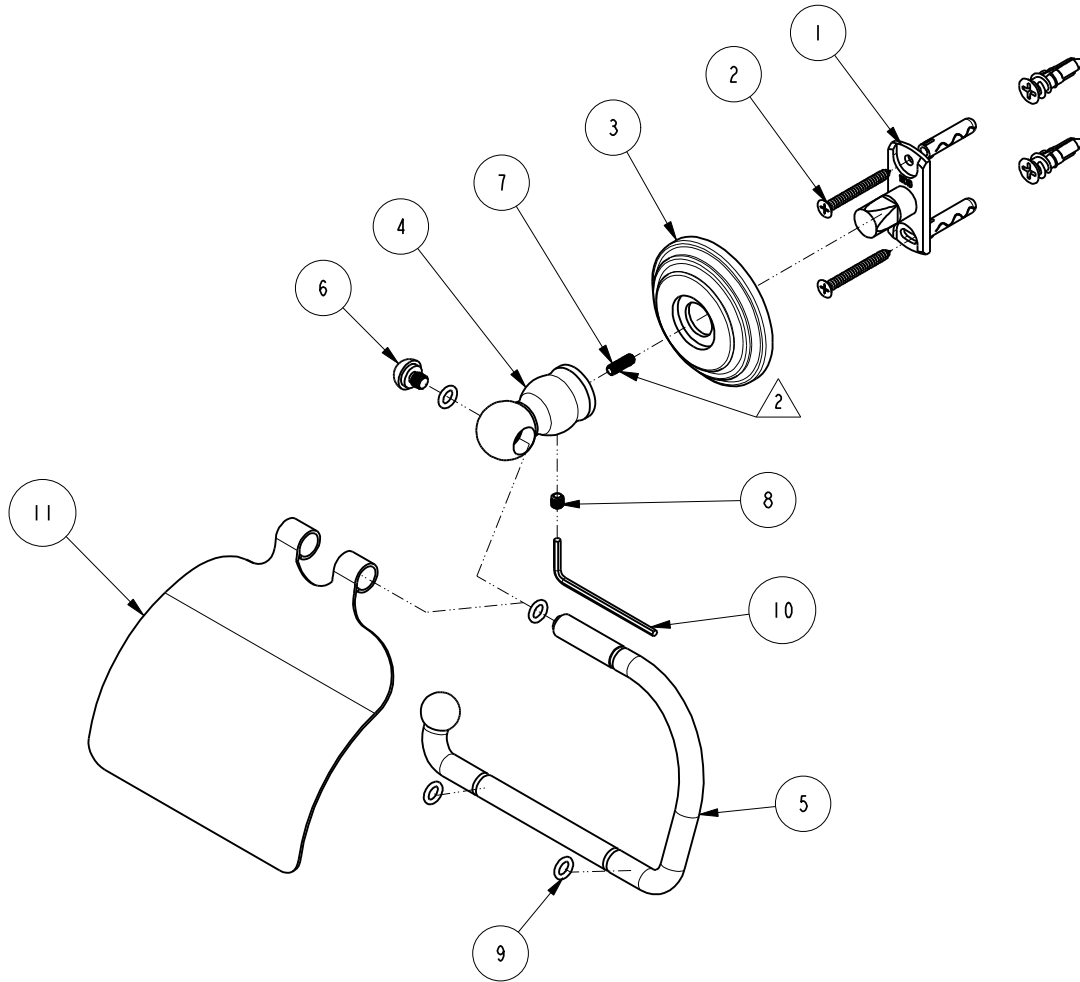

UNITS ARE: INCHES [MM]
TOLERANCES ARE:
FRACTIONS DECIMALS ANGLES
±1/16" .X ±.1 [2.5] ±°
.XX ±.06 [1.5]

(X.XXX) DENOTES CRITICAL DIMS.
ALL THREADS ARE CRITICAL

DRAWN JINSON 07/27/21
CHECKED R.S. 07/27/21
APPROVED R.S. 07/27/21

BRASSTECH 2001 CARNEGIE AVE.
INCORPORATED SANTA ANA, CA 92705
(949) 417-5207

HOODED TOILET TISSUE HOLDER

DWG NO. 1127 REV A

SCALE .312 REF. - SHEET 1 OF 2

COPYRIGHT 2005 BRASSTECH, INC.
THESE DRAWINGS AND THE DESIGNS
DEPICTED HEREIN ARE THE PROPRIETARY
PROPERTY OF BRASSTECH. ANY USE
OR REPRODUCTION IS SUBJECT TO
THE EXPRESS APPROVAL OF BRASSTECH.
UNAUTHORIZED USE IS STRICTLY
PROHIBITED. ALL RIGHTS RESERVED.

TESTING	-	-	-
ASSEMBLY	-	-	-
PLATING	-	-	-
POLISHING	-	NEXT ASSY	USED ON
MACHINING	-	APPLICATION	
TOOLING FIXTURE #	REMOVE ALL BURRS AND SHARP EDGES		

ZONE	REV	DESCRIPTION	DATE	APPROVED
-	A	EN-4378	07/27/21	R.S.
-	-	RELEASED	02/01/04	-

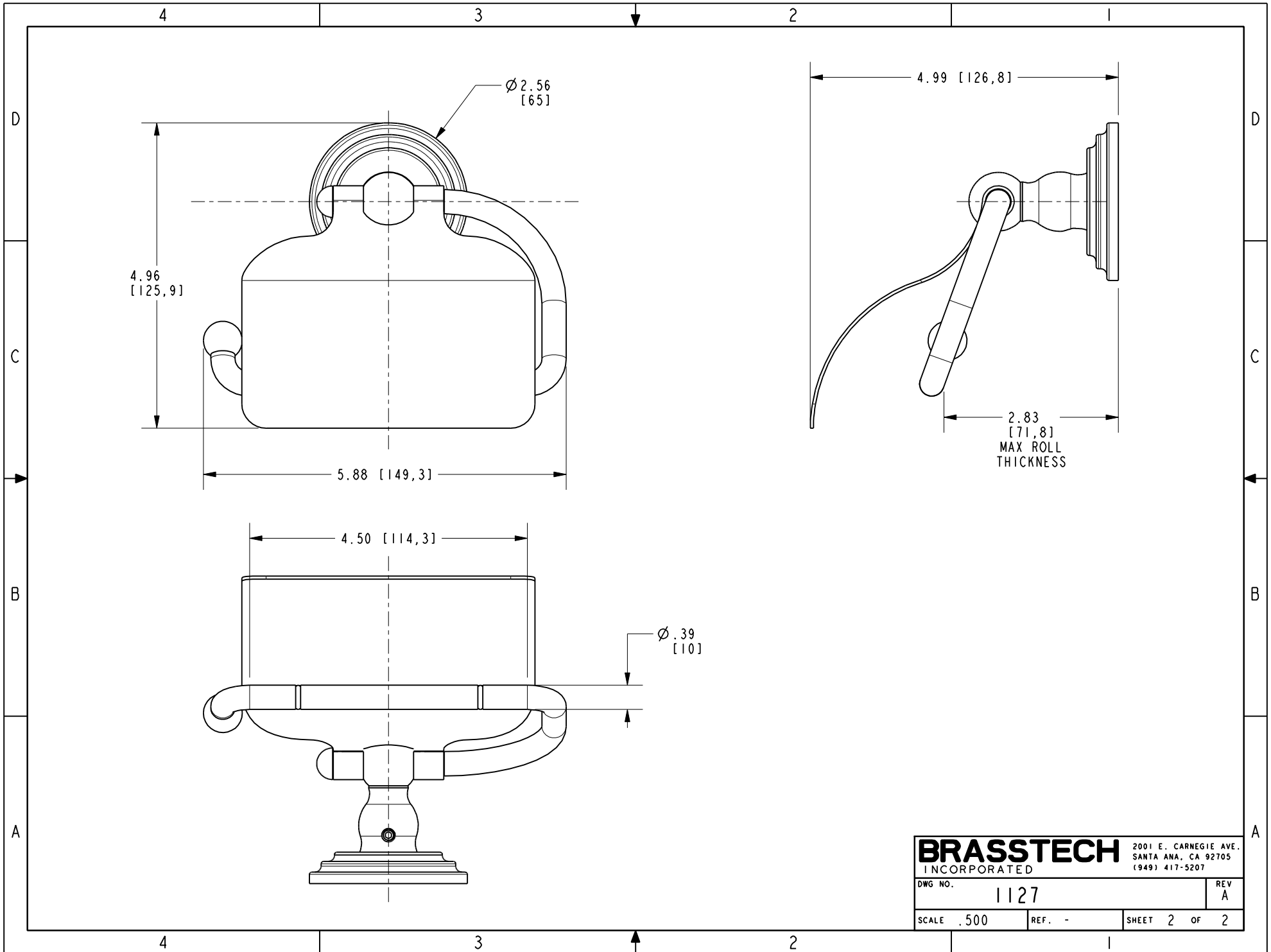

BRASSTECH		2001 E. CARNEGIE AVE. SANTA ANA, CA 92705 (949) 417-5207	
INCORPORATED			
DWG NO.	1127	REV	A
SCALE	.500	REF.	-
		SHEET	2 OF 2