

NOTES:

1. TO INSPECT ASSEMBLY, FOLLOW FIRST ARTICLE AND IN PROCESS INSPECTION SHEET.

BILL OF MATERIAL (CURRENT LEVEL)

ITEM	PT/ASSY	DESCRIPTION	TYPE	QTY.
1	285XX	MOUNTING BRACKET	PART	2
2	1-206	HARDWARE PACK	ASSEMBLY	2
3	7-804	CORNER SHELF ASM	ASSEMBLY	1
4	92035	SCRW, M4 X .7 X 10 PHL FLT HD SS	PART	2

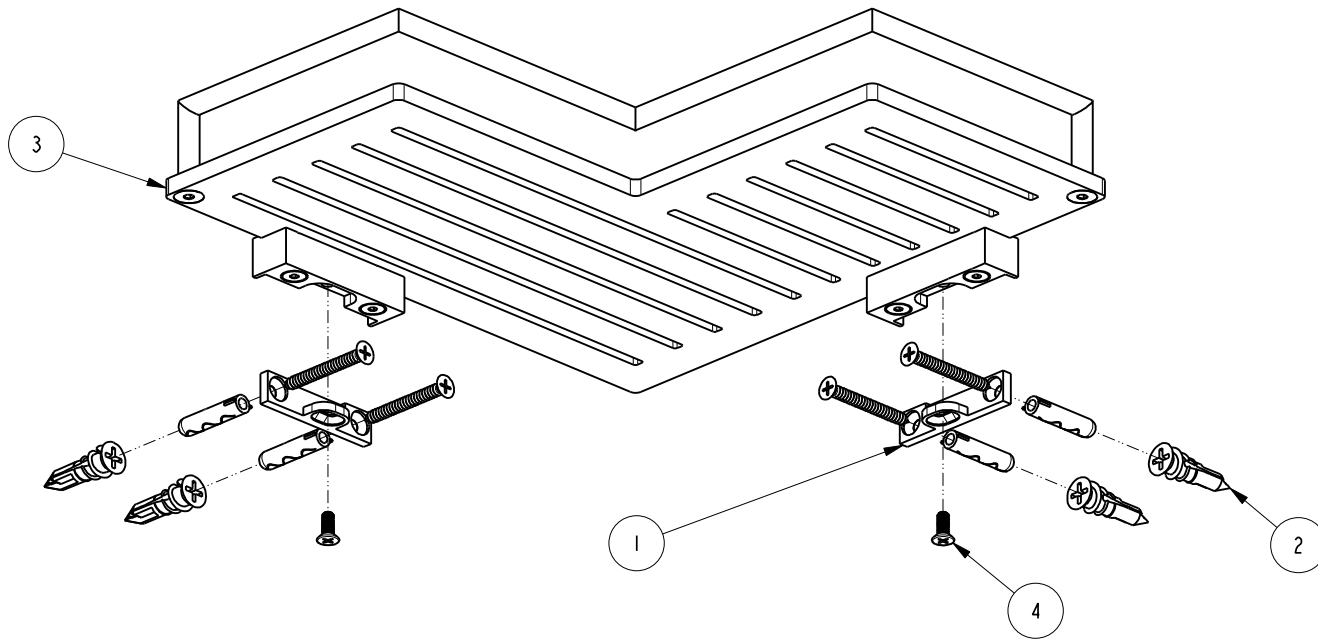
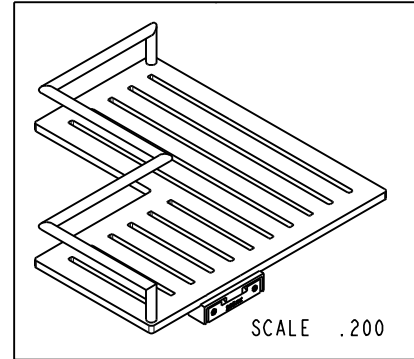

COPYRIGHT 2005 BRASSTECH, INC. THESE DRAWINGS AND THE DESIGNS DEPICTED HEREIN ARE THE PROPRIETARY PROPERTY OF BRASSTECH. ANY USE OR REPRODUCTION IS SUBJECT TO THE EXPRESS APPROVAL OF BRASSTECH. UNAUTHORIZED USE IS STRICTLY PROHIBITED. ALL RIGHTS RESERVED.

TESTING	-	-	-
ASSEMBLY	-	-	-
PLATING	-	-	-
POLISHING	-	NEXT ASSY	USED ON
MACHINING	-	APPLICATION	
TOOLING FIXTURE #	REMOVE ALL BURRS AND SHARP EDGES		

UNITS ARE: INCHES [MM]		
TOLERANCES ARE:		
FRACTIONS DECIMALS	ANGLES	
±1/16"	±°	
.X ±.1 [2.5]		
.XX ±.06 [1.5]		
(X.XXX) DENOTES CRITICAL DIMS.		
ALL THREADS ARE CRITICAL		
DRAWN	JINSON	01/28/22
CHECKED	R.S.	01/28/22
APPROVED	R.S.	01/28/22

BRASSTECH 2001 CARNEGIE AVE.
INCORPORATED SANTA ANA, CA 92705
(949) 417-5207

CORNER SHELF

ZONE	REV	DESCRIPTION	DATE	APPROVED
-	A	EN-4430	01/28/22	R.S.

DWG NO.	28505	REV	A
SCALE	.400	REF.	-
SHEET	1	OF	2

