

NOTES:

(N1) 1. FIT / FORM / FUNCTION SHALL FOLLOW PS-E.008.

2 △ APPLY PERMANENT THREAD LOCKER (LOCTITE 680)

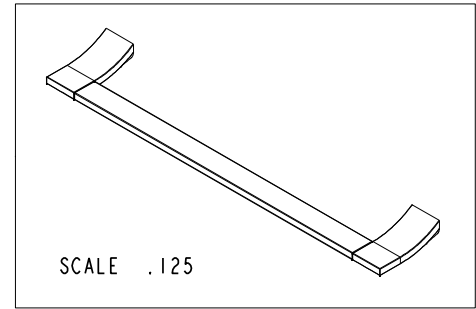
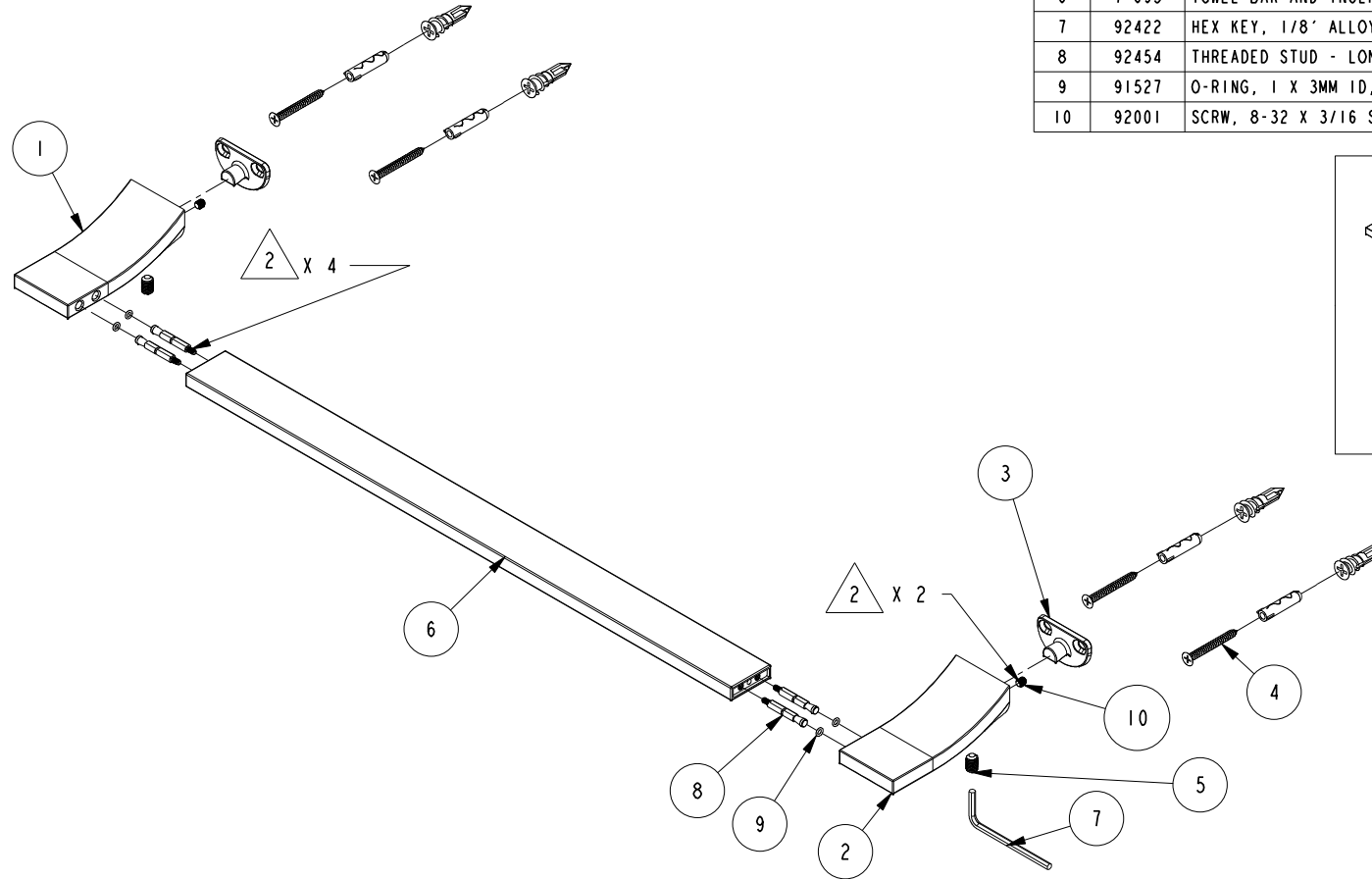

BILL OF MATERIAL (CURRENT LEVEL)				
ITEM	PT/ASSY	DESCRIPTION	TYPE	QTY.
1	40412	TOWEL BAR POST LEFT	PART	1
2	40413	TOWEL BAR POST RIGHT	PART	1
3	92437	MOUNTING BRACKET	PART	2
4	1-206	HARDWARE PACK	ASSEMBLY	2
5	92495	SCRW, 1/4-28 X 3/8 SKT HD CUP PT W/ SELF LOC SS	PART	2
6	7-693	TOWEL BAR AND INSERT ASSY	ASSEMBLY	1
7	92422	HEX KEY, 1/8" ALLOY STEEL	PART	1
8	92454	THREADED STUD - LONG	PART	4
9	91527	O-RING, 1 X 3MM ID, EPDM, 65-75 DURO	PART	4
10	92001	SCRW, 8-32 X 3/16 SKT HD FLT PT SS	PART	2

-	E	EN-4150	03/31/20	R.S.
-	D	EN-4032	12/16/19	R.S.
-	C	EN-1718	04/01/11	J.M.
-	B	EN-1701	02/17/11	J.M.
-	A	EN-1683	01/06/11	J.M.
-	-	EN-1294	11/09/10	J.M.
ZONE	REV	DESCRIPTION	DATE	APPROVED

COPYRIGHT 2005 BRASSTECH, INC. THESE DRAWINGS AND THE DESIGNS DEPICTED HEREIN ARE THE PROPRIETARY PROPERTY OF BRASSTECH. ANY USE OR REPRODUCTION IS SUBJECT TO THE EXPRESS APPROVAL OF BRASSTECH. UNAUTHORIZED USE IS STRICTLY PROHIBITED. ALL RIGHTS RESERVED.

TESTING	-	-	-
ASSEMBLY	-	-	-
PLATING	-	-	-
POLISHING	-	NEXT ASSY	USED ON
MACHINING	-	APPLICATION	
TOOLING FIXTURE #	REMOVE ALL BURRS AND SHARP EDGES		

UNITS ARE: INCHES [MM]	
TOLERANCES ARE:	
FRACTIONS	DECIMALS ANGLES
±1/16"	±.1 [2.5] ±1°
.X	±.06 [1.5]
.XX	±.06 [1.5]
(X.XXX) DENOTES CRITICAL DIMS. ALL THREADS ARE CRITICAL	
DRAWN	R.S. 11/09/10
CHECKED	J.M. 11/09/10
APPROVED	J.M. 11/09/10

BRASSTECH		2001 CARNEGIE AVE. SANTA ANA, CA 92705 (949) 417-5207	
INCORPORATED			
18" TOWEL BAR			
DWG NO.		REV	
4702		E	
SCALE	REF.	SHEET	OF
.250	-	1	2

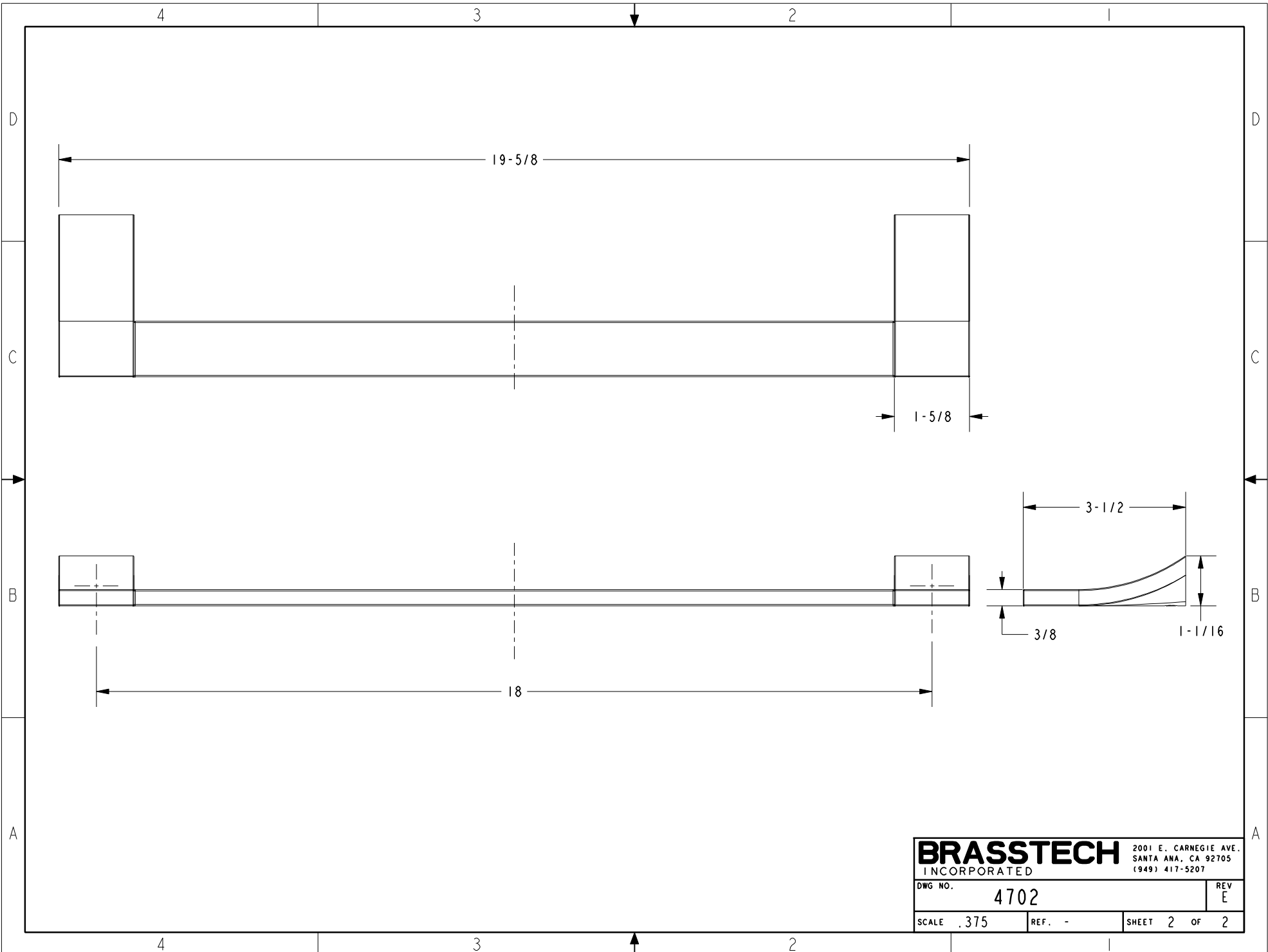

BRASSTECH		2001 E. CARNEGIE AVE. SANTA ANA, CA 92705 (949) 417-5207	
DWG NO.	4702	REV	E
SCALE	.375	REF.	-
		SHEET	2 OF 2