



NOTES:

- (N1) 1. FIT / FORM / FUNCTION SHALL FOLLOW PS-E.008.
- (N2)  2 APPLY LOCTITE 680.
- (N3)  3 APPLY LOCTITE E-00NS HYSOL EPOXY

BILL OF MATERIAL (CURRENT LEVEL)				
ITEM	PT/ASSY	DESCRIPTION	TYPE	QTY.
1	1-206	HARDWARE PACK	ASSEMBLY	1
2	10615	HEX KEY, 3MM ALLOY STEEL	PART	1
3	40506	POST, TOWEL BAR	PART	1
4	40510	A SHAPED RING - TOWEL RING	PART	1
5	40525	END POST, TOWEL RING	PART	1
6	92001	SCRW, 8-32 X 3/16 SKT HD FLT PT SS	PART	1
7	92031	SCRW, M6 X 1 X 6 SKT HD CUP PT SS	PART	1
8	92527	SCRW, 8-32 X 3/8 SKT CAP HD SS	PART	1
9	6XXB	MOUNTING BRACKET	PART	1
10	XX05C	TOWEL RING COUPLER	PART	1

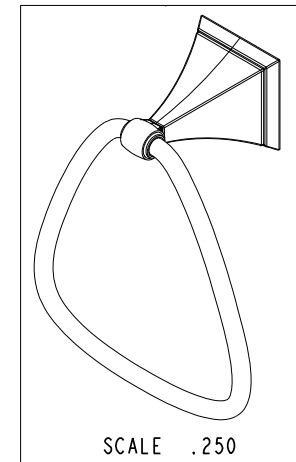
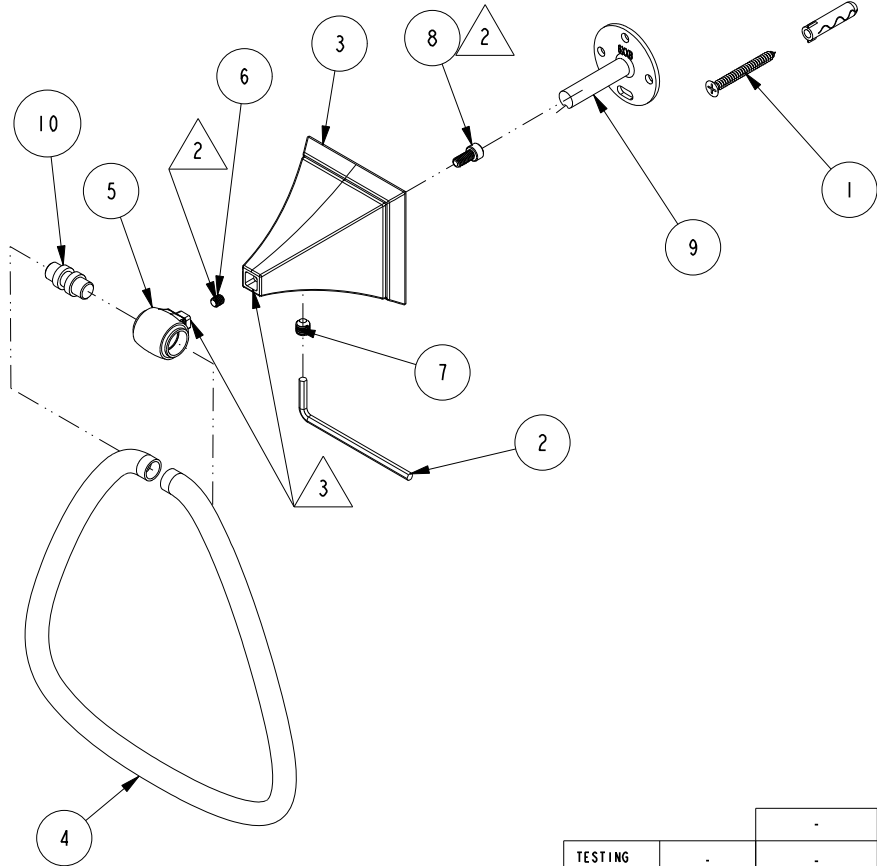

TESTING	-	-	-
ASSEMBLY	-	-	-
PLATING	-	-	-
POLISHING	-	NEXT ASSY	USED ON
MACHINING	-	APPLICATION	
TOOLING FIXTURE #	REMOVE ALL BURRS AND SHARP EDGES		

UNITS ARE: INCHES [MM]
 TOLERANCES ARE:
 FRACTIONS DECIMALS ANGLES
 $\pm 1/16"$ $.X \pm .1$ [2,5] $\pm 1^\circ$
 $.XX \pm .06$ [1,3]

(X.XXX) DENOTES CRITICAL DIMS.
 ALL THREADS ARE CRITICAL

BRASSTECH 2001 CARNEGIE AVE.
 INCORPORATED SANTA ANA, CA 92705
 (949) 417-5207

'A' - SHAPE TOWEL RING

DWG NO. 4905

SCALE .313 REF. - SHEET 1 OF 2

-	A	EN-2996	01/04/16	J.M.
-	-	EN-2087	09/20/13	-
ZONE	REV	DESCRIPTION	DATE	APPROVED

COPYRIGHT 2005 BRASSTECH, INC.
 THESE DRAWINGS AND THE DESIGNS
 DEPICTED HEREIN ARE THE PROPRIETARY
 PROPERTY OF BRASSTECH. ANY USE
 OR REPRODUCTION IS SUBJECT TO
 THE EXPRESS APPROVAL OF BRASSTECH.
 UNAUTHORIZED USE IS STRICTLY
 PROHIBITED. ALL RIGHTS RESERVED.

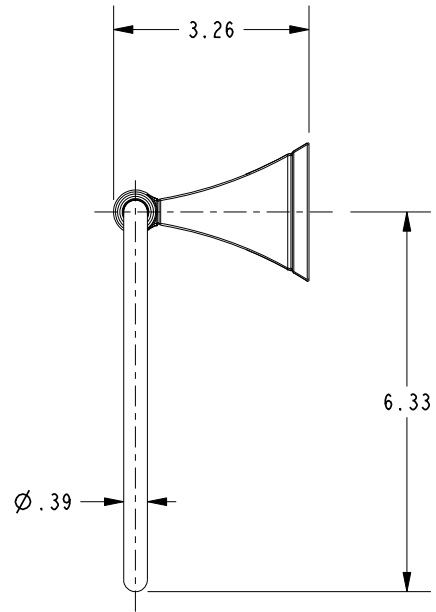
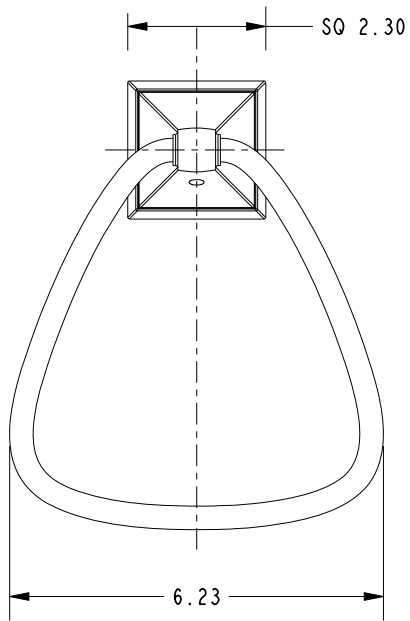

BRASSTECH		2001 E. CARNEGIE AVE.	
INCORPORATED		SANTA ANA, CA 92705	
		(949) 417-5207	
DWG NO.	4905	REV	A
SCALE .313	REF. -	SHEET 2	OF 2