

NOTES:

- (N1) 1. FIT / FORM / FUNCTION SHALL FOLLOW PS-E.008.
- (N2) 2. APPLY LOCTITE 680.
- (N3) 3. PLACE ITEMS# 2 AND 9 IN A SEPARATE BAG

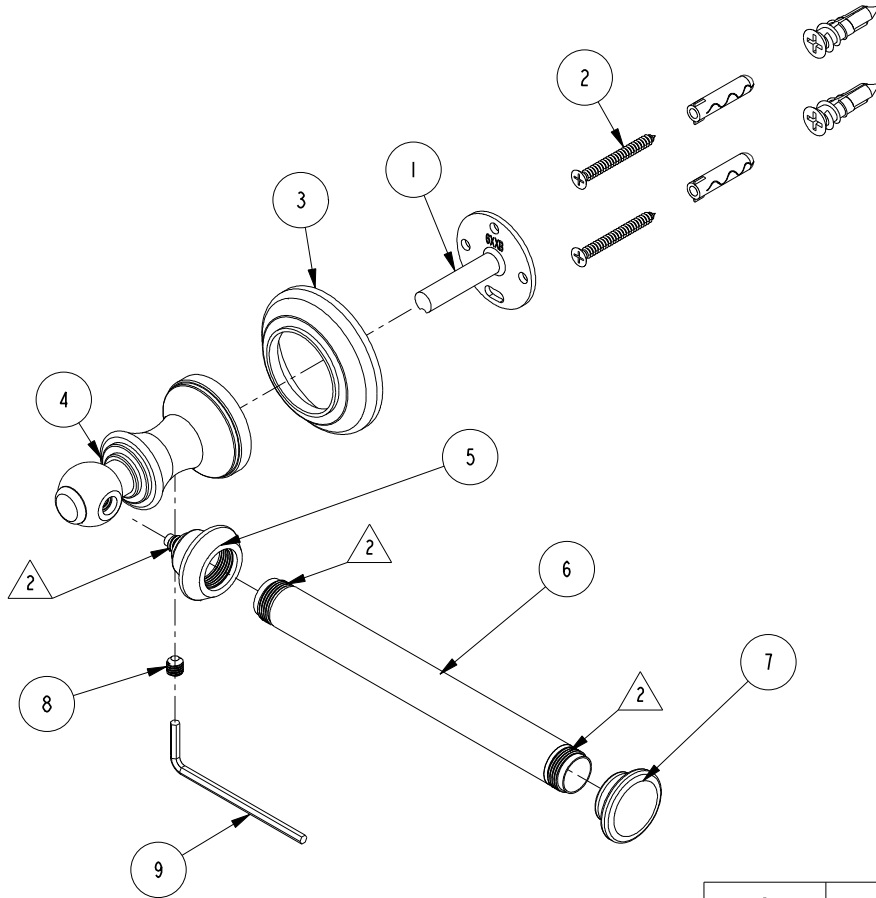

**BILL OF MATERIAL (CURRENT LEVEL)**

ITEM	PT/ASSY	DESCRIPTION	TYPE	QTY.
1	6XXB	MOUNTING BRACKET	PART	1
2	1-206	HARDWARE PACK	ASSEMBLY	1
3	2-656	HANDLE ESCUTCHEON ASM	ASSEMBLY	1
4	40720	TOWEL BAR POST LEFT	PART	1
5	40740	FINIAL, SINGLE TISSUE HOLDER	PART	1
6	40741	TUBE, TISSUE HOLDER	PART	1
7	40742	FINIAL	PART	1
8	92031	SCRW, M6 X 1 X 6 SKT HD CUP PT W/ SELF LOC SS	PART	1
9	10615	HEX KEY, 3MM ALLOY STEEL	PART	1

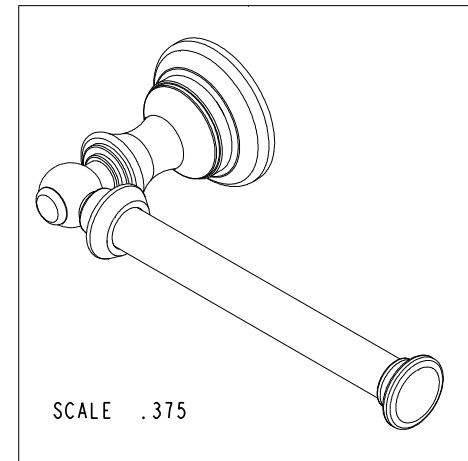

COPYRIGHT 2005 BRASSTECH, INC. THESE DRAWINGS AND THE DESIGNS DEPICTED HEREIN ARE THE PROPRIETARY PROPERTY OF BRASSTECH. ANY USE OR REPRODUCTION IS SUBJECT TO THE EXPRESS APPROVAL OF BRASSTECH. UNAUTHORIZED USE IS STRICTLY PROHIBITED. ALL RIGHTS RESERVED.

TESTING	-	-	-
ASSEMBLY	-	-	-
PLATING	-	-	-
POLISHING	-	NEXT ASSY	USED ON
MACHINING	-	APPLICATION	
TOOLING FIXTURE #	REMOVE ALL BURRS AND SHARP EDGES		

UNITS ARE: INCHES [MM]		
TOLERANCES ARE:		
FRACTIONS	DECIMALS	ANGLES
±1/16"	.X ±.1 [2.5]	±1°
	.XX ±.06 [1.5]	
(X.XXX) DENOTES CRITICAL DIMS. ALL THREADS ARE CRITICAL		
DRAWN	R.S.	06/21/19
CHECKED	J.M.	06/21/19
APPROVED	J.M.	06/21/19

**BRASSTECH** 2001 CARNEGIE AVE.  
INCORPORATED SANTA ANA, CA 92705  
(949) 417-5207

**TOILET TISSUE HOLDER**

-	-	EN-3841	06/21/19	J.M.
ZONE	REV	DESCRIPTION	DATE	APPROVED

DWG NO.	5606	REV	-
SCALE	.375	REF.	-
SHEET	1	OF	2

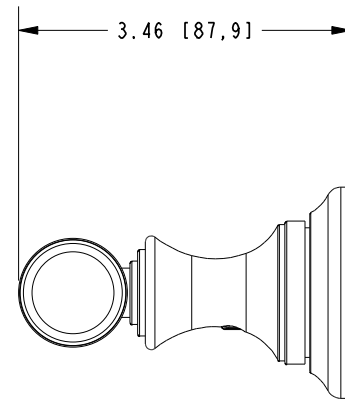
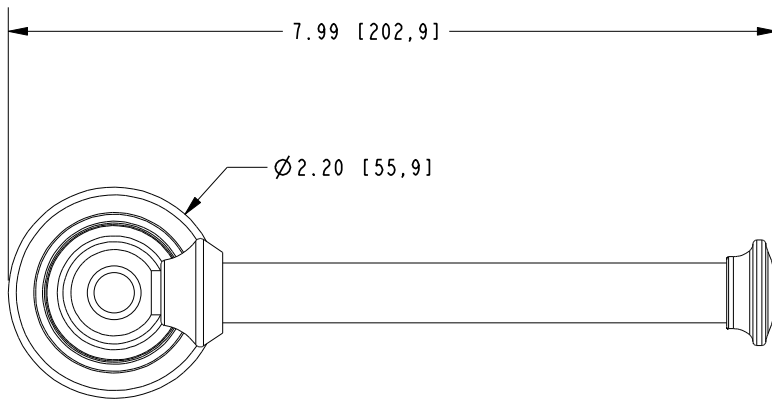

<b>BRASSTECH</b>		2001 E. CARNEGIE AVE. SANTA ANA, CA 92705 (949) 417-5207	
DWG NO.	5606	REV	-
SCALE	.500	REF.	-
		SHEET	2 OF 2